

# Inox Sanitary Filter Housings

## Single Cartridge and Multi-Cartridge

Beverage and pharmaceutical production requires crevice-free pipework and equipment to reduce the possibility of microbiological growth within the system. SPECTRUM Inox Sanitary filter housings meet these requirements, as well as Good Manufacturing Practice (GMP) design guidelines, with an industry leading internal surface finish of  $0.3\mu\text{m}$  roughness average (Ra). Satisfying industry requirements, housings are supplied with tri-clamp inlet and outlet ports, with sanitary drain ports for complete draining of the vessel during clean down procedures and a sanitary pressure gauge.

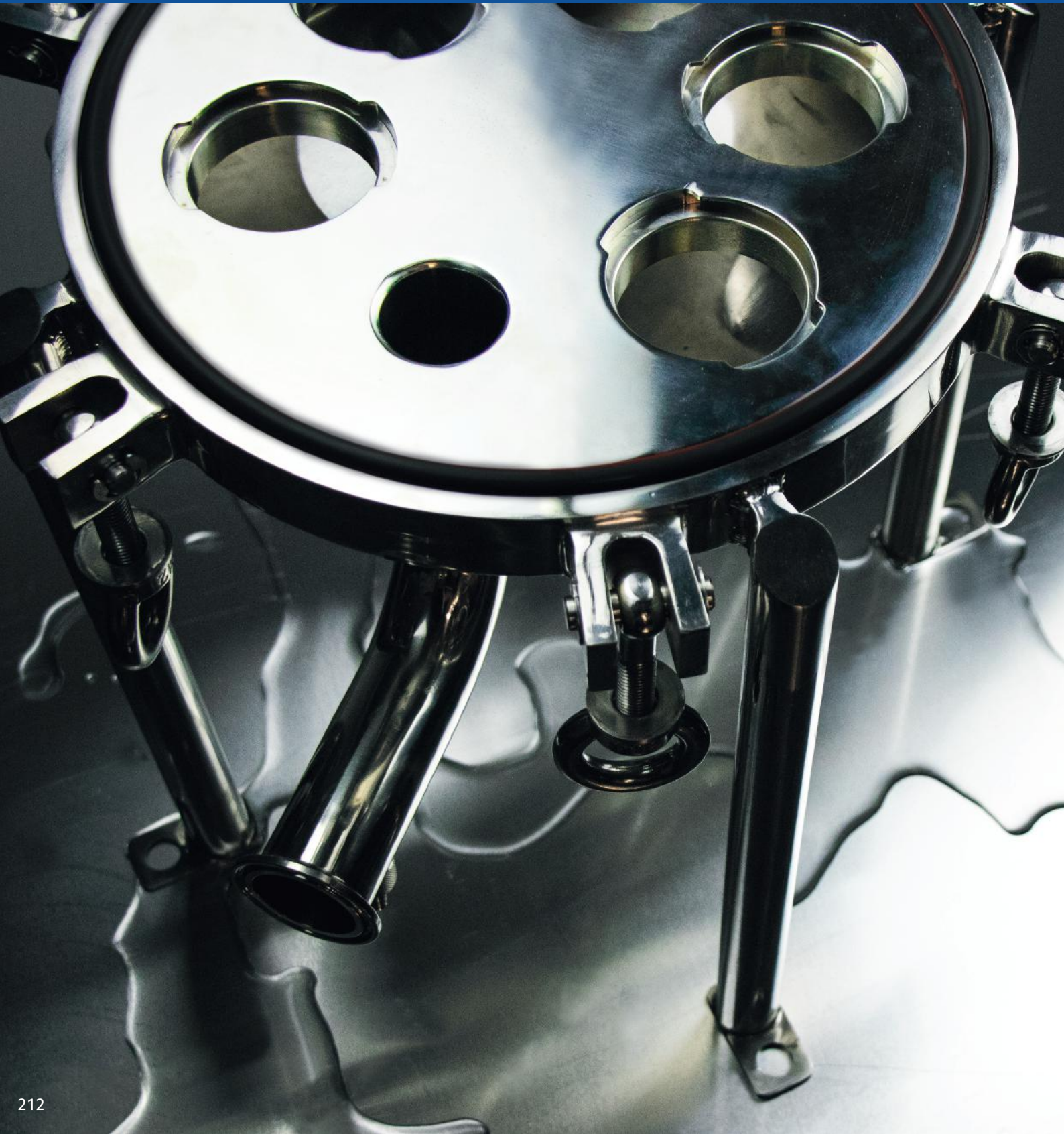

## Cartridge Compatibility

For the most sterile of applications, the industry go-to cartridge is a 226 double O-ring filter with locking tabs. The Inox Sanitary range accepts this seal with the option of a fin or recessed end-cap, enabling a tight and secure "twist" sealing mechanism.

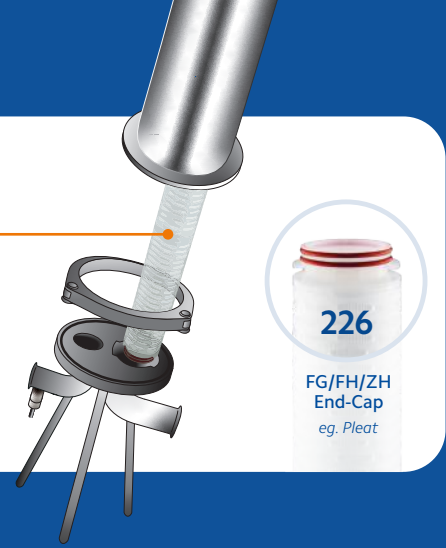

**1 Cartridge**

**up to 60 lpm**



**3 Cartridges**

**up to 180 lpm**

**5 Cartridges**

**up to 400 lpm**



**7 Cartridges**

**up to 560 lpm**



## Which Size Housing?

SPECTRUM Sanitary housings range in size from single round to 7 round, with flow rates up to 560 litres per minute.

# Inox Sanitary Filter Housings

## Features

Engineered to the highest standard, these housings have gone through an extensive design process to control microbiological adhesion and promote continued high-quality final product. The range is manufactured from 316L stainless steel and machine polished to produce a crevice-free finish, suitable for full sanitisation and clean down (SIP/CIP). Tri-clamp connections and a swing bolts provide efficient cartridge changeout, eliminating the need for additional tools and reducing system downtime.

### Pressure Gauge

Specifically designed for sanitary housings, the diaphragmed pressure gauge reduces potential contamination whilst providing easy filter monitoring.

### Tri-Clover Clamps

Used to secure inlet & outlet ports as well as a pressure gauge.

### Vent/Test Port

For pressure release and integrity testing.

### Integrity Tester

To measure filter cartridge properties before, during and after batch runs. PES-IT sold separately.

### Traceability

Each housing has a serial number for product traceability.

### Drain Port

Ensures efficient drainage to aid housing cleaning. Larger housings have two ports to reduce product wastage.



## Industrial

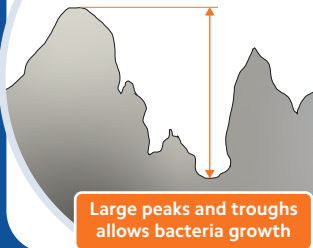

## Sanitary

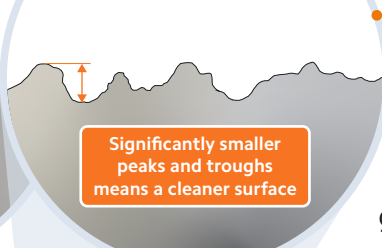

## Surface Finish

Typically, sanitary grade products are polished to a 0.5-0.8µm Ra finish. Inox Sanitary housings exceed this specification, with an internal surface roughness of 0.3µm creating a crevice-free finish, inhibiting the growth of bacteria and other unwanted contaminants.

### Handles

In order to make cartridge changeout easy, handles are positioned on either side of the body.

### Housing Body

Highly polished internal and external mirror smooth surfaces reduce microbial adhesion and potential contamination.

### Secure Seal

226 end-capped cartridges lock easily into place with a simple twist.

### O-ring

Made from EPDM, this provides a positive sealing of the housing body and base.



### Eye Bolt

For closure security and operator ease.

### Sight Glass

Easily added inline with pipework to provide a visible quality check of the filtrate. PSFH-SG-2 sold separately.

### Legs

3,5 & 7 round housings are fitted with fixed legs. The 1 round housings have screw-on tripod legs.

# Sanitary Filter Housing

## 1 Cartridge Round

Providing the most flexible option within the Sanitary range in terms of cartridge lengths and port sizes, the single round housing provides a tailored solution for flow rates up to 60 litres per minute. Utilising a tri-clamp closure to cleanly secure the body to the base, this range is supplied as a complete package with a gauge, tripod legs, valved vent and drain ports as well as blanking plates for any unused ports.

Up to 60 lpm



**FDA**  
Compliant Materials

**PED**  
Compliant  
Article 4, Paragraph 3  
Group 2 Liquids

**DWI**  
Approved

 **SPECTRUM**



## Technical Drawing

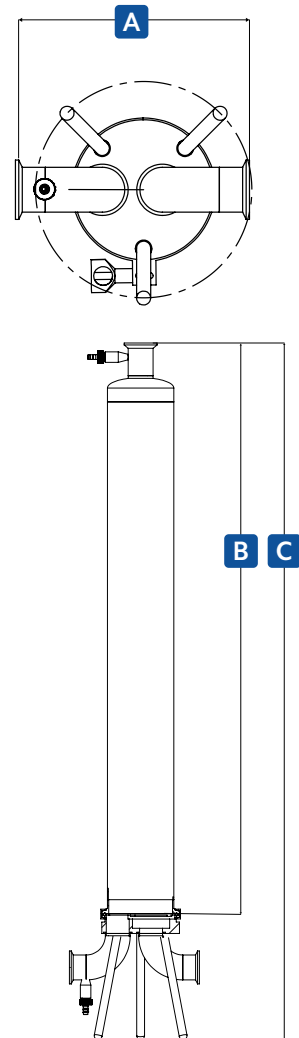

### Dimensions (mm)

Housing	A	B	C
PSFH-SEP-1-10	198	369	548
PSFH-SEP-1-20	198	623	802
PSFH-SEP-1-30	198	877	1056
PSFH-SEP-1-30-1.5	198	877	1056



## Key Features

- 0.3µm Ra internal surface finish
- Tri-clamp ports for industry compatibility
- Diaphragmed pressure gauge included for filter monitoring
- Vent / test port for pressure release and integrity testing
- Accepts 226 end-cap for added security

## Flow Rate (lpm)

Pleated

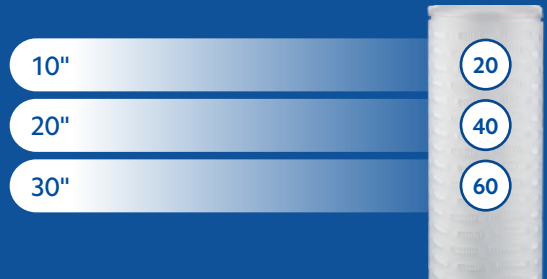

## Specification

Port Sizes (Tri-Clamp")



Cartridge Compatibility (")



End-Cap Compatibility



226  
FG/FH/ZH  
Ended  
eg. Bubble Point

Temperature (°C)



Pressure Rating (bar)\*



Materials

Body & Base - 316L Stainless Steel
Internal Surface Finish - ≤ 0.3µm Ra
External Surface Finish - ≤ 0.4µm Ra
Housing Seal - EPDM

\* Hydrostatic Pressure Rating

### Vent/Test Port

For pressure release and integrity testing.

### Sanitary Pressure Gauge

Fitted with tri-clamp, this measures incoming liquid pressure.

### Surface Finish

Highly polished internal and external mirror smooth surfaces reduce microbial adhesion and potential contaminants.

### Cartridge Compatibility

Suitable for 226 fin/closed cartridges.

### Locking Clamp

Industry standard, quick and secure locking.

### O-ring

EPDM O-ring provides seal.

### Inlet

1" or 1½" tri-clamp options.

### Outlet

1" or 1½" tri-clamp options.

### Drain Port

Ensures efficient drainage to aid housing cleaning.

### Mounting Legs

Tripod legs offer stability.



Code	Description
PSFH-SEP-1-10-1-226E	SPECTRUM Sanitary Filter Housing 1 x 10 226 End-Cap 1" Tri-Clamp EPDM Seal
PSFH-SEP-1-20-1-226E	SPECTRUM Sanitary Filter Housing 1 x 20 226 End-Cap 1" Tri-Clamp EPDM Seal
PSFH-SEP-1-30-1-226E	SPECTRUM Sanitary Filter Housing 1 x 30 226 End-Cap 1" Tri-Clamp EPDM Seal
PSFH-SEP-1-30-1.5-226E	SPECTRUM Sanitary Filter Housing 1 x 30 226 End-Cap 1.5" Tri-Clamp EPDM Seal



# Sanitary Filter Housing

## 3 Cartridge Round

One of the most popular sizes of sanitary housing throughout the Beverage industry, the 3 round configuration boasts a flow rate capacity up to 180 litre per minute. With the swing bolt and eye nut closure mechanism, tool-free cartridge changeout reduces system downtime and operator labour. The 2" inlet and outlet ports provide compatibility with housing accessories such as the sanitary sight glass for visual filtrate validation.

Up to 180 lpm



**FDA**  
Compliant Materials

**PED**  
Compliant  
Article 4, Paragraph 3  
Group 2 Liquids

**DWI**  
Approved

**SPECTRUM**

### Technical Drawing

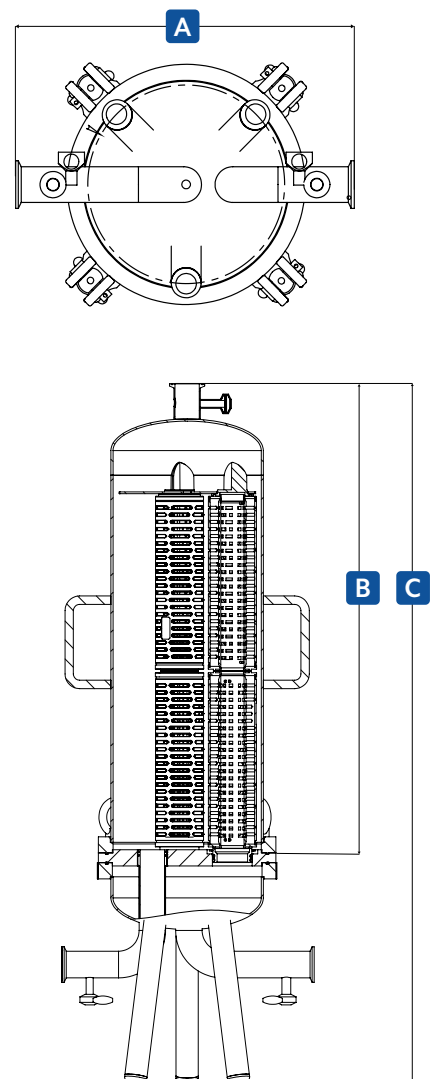

Dimensions (mm)			
Housing	A	B	C
PSFH-SEP-3-30	360	930	1250



## Key Features

- 0.3µm Ra internal surface finish
- Tri-clamp ports for industry compatibility
- Diaphragmed pressure gauge included for filter monitoring
- Vent / test port for pressure release and integrity testing
- Accepts 226 end-cap for added security



## Flow Rate (lpm)

Pleated

30"

180



## Specification

Port Sizes (Tri-Clamp")

2

Cartridge Compatibility (")

30

End-Cap Compatibility



226  
FG/FH/ZH  
Ended  
eg. Bubble Point

Temperature (°C)

150

Pressure Rating (bar)\*

12.5

Materials

Body & Base - 316L Stainless Steel

Internal Surface Finish - ≤ 0.3µm Ra

External Surface Finish - ≤ 0.4µm Ra

Housing Seal - EPDM

\* Hydrostatic Pressure Rating

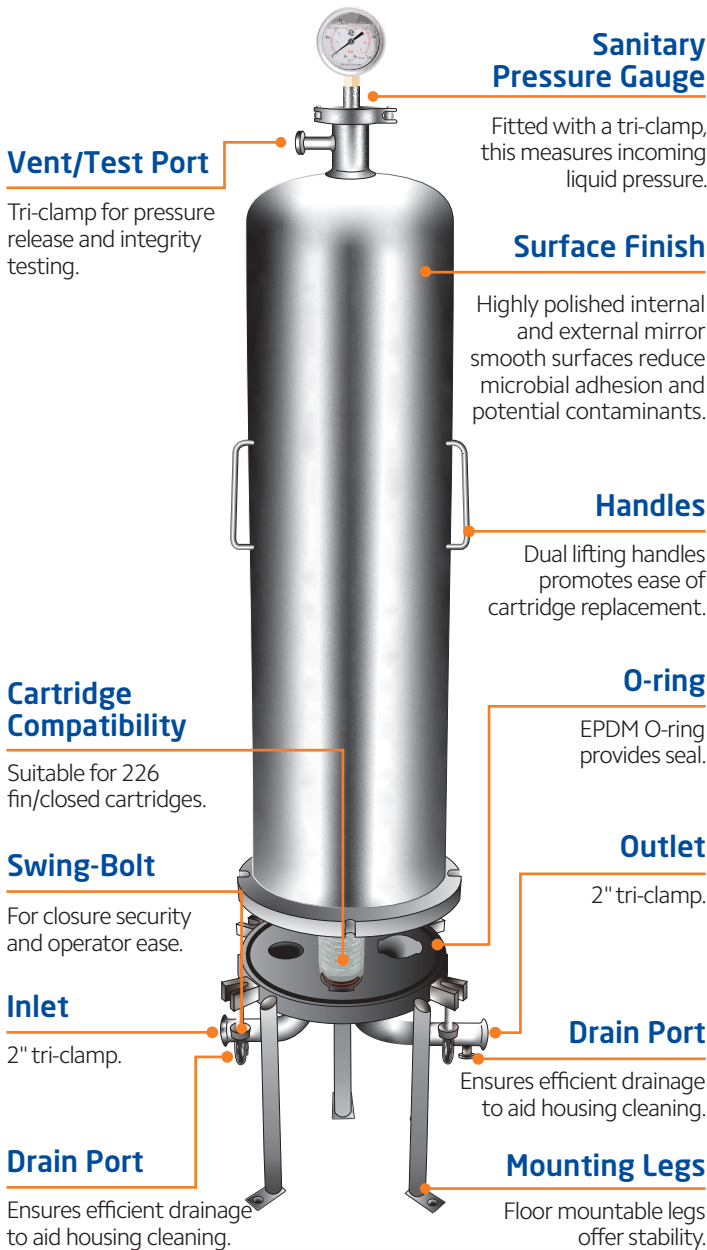

Code	Description
PSFH-SEP-3-30-2-226E	SPECTRUM Sanitary Filter Housing 3 x 30 226 End-Cap 2" Tri-Clamp EPDM Seal





# Sanitary Filter Housing

## 5 Cartridge Round

Extending flow rate capability, the 5 round Sanitary housing is the first of the multi-round configurations to offer the benefit of future proofing application requirements. System capacity can be increased by 33%, without any pipework adjustments by simply exchanging a 30" body for the 40" version. The swing bolt closure mechanism assists cartridge changeout even in these larger configurations.

Up to 400 lpm



**FDA**  
Compliant Materials

**PED**  
Compliant  
Article 4, Paragraph 3  
Group 2 Liquids

**DWI**  
Approved

**SPECTRUM**



### Technical Drawing

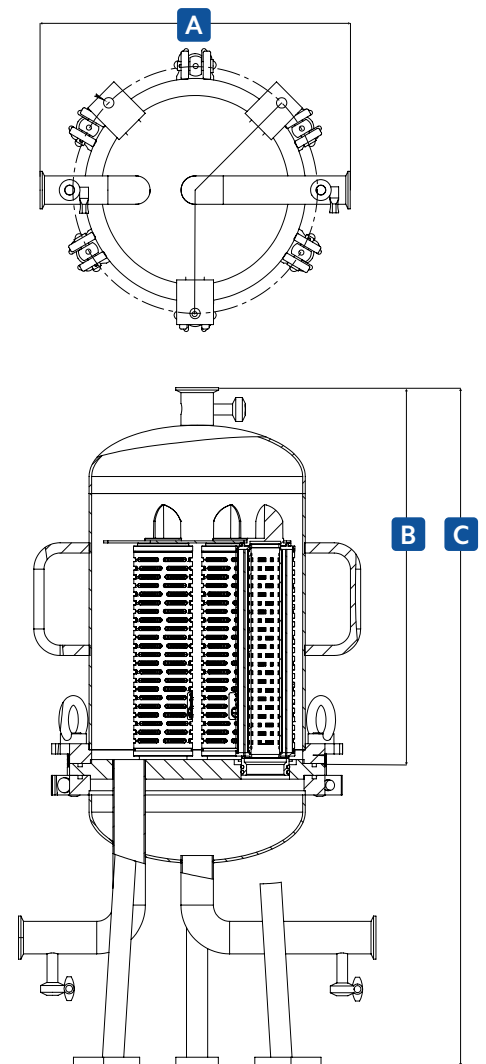

Dimensions (mm)			
Housing	A	B	C
PSFH-SEP-5-30	420	940	1280
PSFH-SEP-5-40	420	1190	1530



## Key Features

- 0.3µm Ra internal surface finish
- Tri-clamp ports for industry compatibility
- Diaphragmed pressure gauge included for filter monitoring
- Vent / test port for pressure release and integrity testing
- Accepts 226 end-cap for added security

## Flow Rate (lpm)

Pleated

30"

300

40"

400

## Specification

Port Sizes (Tri-Clamp")

2

Cartridge Compatibility (")

30

40

End-Cap Compatibility



226

FG/FH/ZH  
Ended  
eg. Bubble Point

Temperature (°C)

150

Pressure Rating (bar)\*

12.5

Materials

Body & Base - 316L Stainless Steel

Internal Surface Finish - ≤ 0.3µm Ra

External Surface Finish - ≤ 0.4µm Ra

Housing Seal - EPDM

\* Hydrostatic Pressure Rating

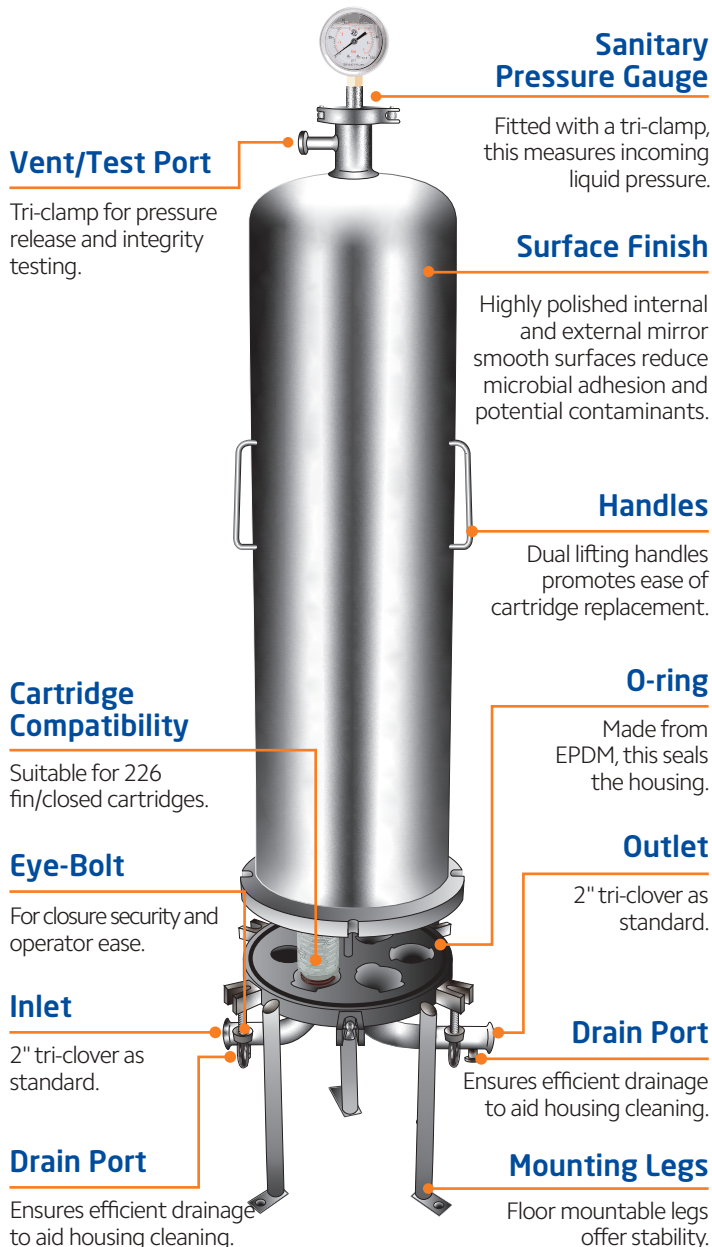

Code	Description
PSFH-SEP-5-30-2-226E	SPECTRUM Sanitary Filter Housing 5 x 30 226 End-Cap 2" Tri-Clamp EPDM Seal
PSFH-SEP-5-40-2-226E	SPECTRUM Sanitary Filter Housing 5 x 40 226 End-Cap 2" Tri-Clamp EPDM Seal



# Sanitary Filter Housing

## 7 Cartridge Round

The largest variation in the Inox Sanitary housing range, the 7 round provides a comprehensive solution for precise applications up to 560 litres per minute. Implementing industry specified and user-focused features, these larger vessels do not compromise in terms of quality or functionality. With a sanitary pressure gauge, vent and drain ports, floor mountable legs, as well as blanking plates for any unused ports, the range is supplied as a complete package for peace of mind.

Up to 560 lpm



**FDA**  
Compliant Materials

**PED**  
Compliant  
Article 4, Paragraph 3  
Group 2 Liquids

**DWI**  
Approved

 **SPECTRUM**



### Technical Drawing

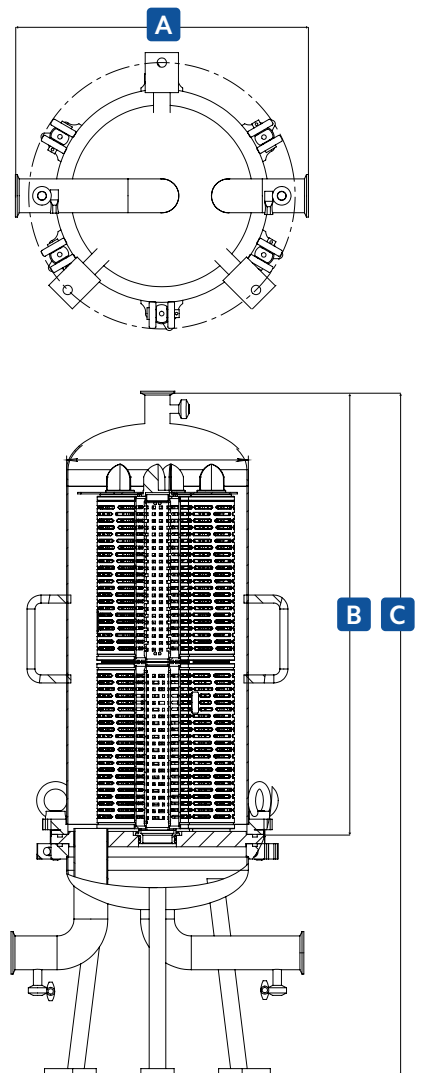

#### Dimensions (mm)

Housing	A	B	C
PSFH-SEP-7-30	440	944	1288
PSFH-SEP-7-40	440	1194	1538



## Key Features

- 0.3µm Ra internal surface finish
- Tri-clamp ports for industry compatibility
- Diaphragmed pressure gauge included for filter monitoring
- Vent / test port for pressure release and integrity testing
- Accepts 226 end-cap for added security

## Flow Rate (lpm)

Pleated

30"

420

40"

560

## Specification

Port Sizes (Tri-Clamp")

2

Cartridge Compatibility (")

30

40

End-Cap Compatibility



FG/FH/ZH  
Ended  
eg. Bubble Point

Temperature (°C)

150

Pressure Rating (bar)\*

12.5

Materials

Body & Base - 316L Stainless Steel

Internal Surface Finish - ≤ 0.3µm Ra

External Surface Finish - ≤ 0.4µm Ra

Housing Seal - EPDM

\* Hydrostatic Pressure Rating

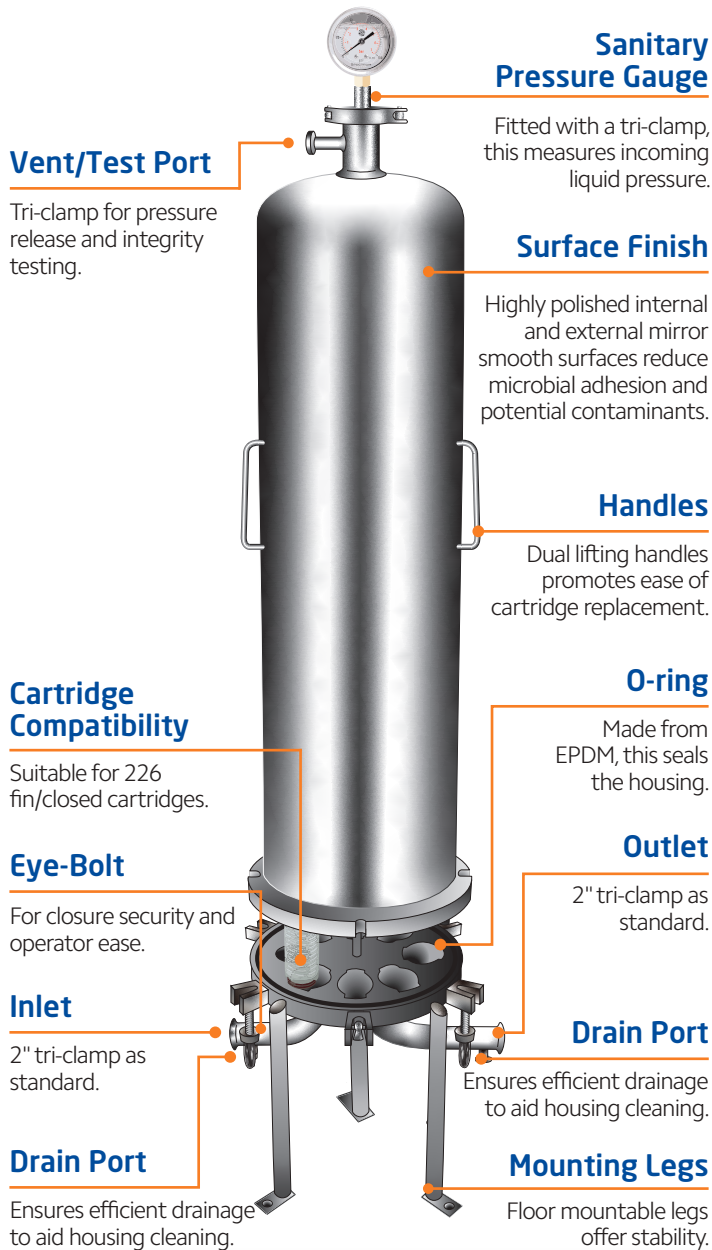

Code	Description
PSFH-SEP-7-30-2-226E	SPECTRUM Sanitary Filter Housing 7 x 30 226 End-Cap 2" Tri-Clamp EPDM Seal
PSFH-SEP-7-40-2-226E	SPECTRUM Sanitary Filter Housing 7 x 40 226 End-Cap 2" Tri-Clamp EPDM Seal

